



LK Minipress V3-19kN

MAP219FLMLK



Serialnumber

Abb. ähnlich / pic. similar
HE.20065_B © 11/2021 R&D-2



**Hydraulic
Pressure
Check**





LK Minipress V3-19kN



Klauke
Auf dem Krapp 46
D-42855
Remscheid

Klauke
Auf dem Krapp 46
D-42855
Remscheid

304711
XN
142

batch# e.g. 304711
datecode e.g. X = 2027; N = Jan.
consecutive# e.g. „142“ = tool # 142
datecode

Year	Code	Month	Code	Month	Code
2022	R	Jan.	N	July	V
2023	S	Feb.	P	Aug.	W
2024	T	Mar.	Q	Sept.	X
2025	V	Apr.	R	Oct.	Y
2026	W	May	S	Nov.	Z
2027	X	June	T	Dec.	1

optional:
BL1840 (RAL40)





 **WARNING**

Read all safety warnings, instructions, illustrations and specifications provided with this power tool.

(GB) *Failure to follow all instructions listed below may result in electric shock, fire and/or serious injury.*

Save all warnings and instructions for future reference.

Läs alla säkerhetsvarningar, instruktioner, illustrationer och specifikationer för detta verktyg.

(S) *Missaktande av alla instruktioner kan medföra elstötar, brand och/eller allvarliga skador.*

Spara alla varningar och instruktioner för framtida bruk.

Les alle sikkerhetsadvarsler, instruksjoner, illustrasjoner og spesifikasjoner som følger med dette verktøyet.

(FIN) *Hvis instruksjonene nedenfor ikke følges, kan det føre til elektrisk støt, brann og/eller alvorlige personskader.*

Oppbevar alle advarsler og instruksjoner for fremtidig bruk.

Lue kaikki tähän koneeseen liittyvät turvallisuusvaroitukset, ohjeet, kuvat ja tekniset tiedot.

(N) *Alla lueteltujen ohjeiden laiminlyönti voi aiheuttaa sähköiskun, tulipalon ja/tai vakavan vamman.*

Säästä kaikki varoitukset ja ohjeet tulevaa tarvetta varten.

Læs alle sikkerhedsforskrifter, instruktioner, illustrationer og specifikationer, der følger med dette el-værktøj.

(DK) *Manglende overholdelse af alle instruktioner i det følgende kan medføre elektrisk stød, brand og/eller alvorlig personskade.*

Gem alle advarsler og instruktioner til fremtidig brug.





LK Minipress V3-19kN

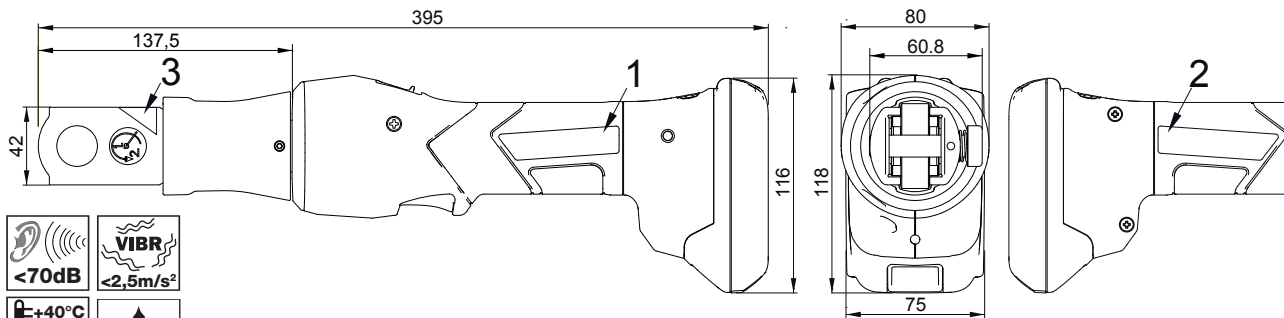

 <70dB	 VIBR <2,5m/s²
 +40°C -10°C	 BIO
 1,8 kg	 19 kN

1

HE: 10215

LK Systems AB • www.lksystems.se

2

MAP219FLM
made by **Klauke**
Pressing tool • 19 kN • 18V ---
For use only with 18V Makita Battery

HE: 10499

3





Applications / Applikationer / Bruksområder / Käyttöalueet / Anvendelser

Scope of accessories Tillbehör Medfølgende tilbehør Tarvikkeiden tarkoitus Tilbehør

Type Typ Type Tyyppi Type	SBMX

Stainless steel, steel Rostfritt stål, stål Rustfritt stål, stål Ruostumaton teräs, teräs Rustfrit stål, stål	max. 35 mm * maks. 35 mm *
Copper, copper alloys Koppar, kopparledningar Kobber, kobberlegeringer Kupari, kupariseokset Kobber, kobberlegeringer	
Multi-layer composite pipe/PEX pipe Flerskiktet kompositrør/PEX-rør Flerlags komposittrør / PEX-rør Monikerroksinen komposiittiputki/PEX-putki Flerlags kompositrør/PEX-rør	max. 40 mm * maks. 40 mm *
<p>* These values are system-related Please contact your system supplier for binding information</p> <p>* Dessa värden baserar på system Vänligen kontakta din återförsäljare för mer information</p> <p>* Disse verdiene er systemavhengige Ta kontakt med leverandøren av systemet for å få bindende opplysninger</p> <p>* Nämä arvot ovat järjestelmään liittyviä Pyydä sitovaa tietoa järjestelmän toimittajalta</p> <p>* Disse værdier er system-relaterede Kontakt din systemleverandør for bindende information</p>	





Attention

(GB)

Please follow the general installation/mapping instructions as well as the operation and Service instructions of the company Gustav Klauke including the respective written notes on the application range as well as installation and mapping instructions of the system supplier.

Please observe the current generally accepted technical rules as well as all applicable laws and directives for the intended installation/mapping.

These values are system-related. Please contact your system supplier for binding information.



Observera

(S)

Följ allmänt gällande installationsinstruktioner samt instruktioner för drift, hantering och service från firma Gustav Klauke inklusive skriftliga uppgifter om användningsområde och systemtillverkarens installationsinstruktioner.

Följ även avsedd användning med hänsyn till gällande tekniska regler samt gällande lagar och förordningar.

Dessa värden baserar på system. Vänligen kontakta din



Merk!

(FIN)

Følg de generelle instruksjonene om installasjon/tilordning samt drifts- og serviceveiledningen fra firmaet Gustav Klauke inkludert medfølgende skriftlige merknader om bruksområder og instruksjoner om installasjon og tilordning fra systemleverandøren.

Følg gjeldende generelle tekniske regler og gjeldende lover og direktiver for den planlagte installasjonen/tilordningen.

Disse verdiene er systemavhengige. Ta kontakt



Huomio

(N)

Noudata Gustav Klauken yleisiä asennus-/kartoitusohjeita sekä käyttö- ja huolto-ohjeita sekä käyttöaluetta koskevia vastaavia kirjallisia ilmoituksia kuin myös järjestelmän toimittajan asennus- ja kartoitusohjeita.

Noudata aiotussa asennus-/kartoitustarkoituksessa nykyisiä yleisesti hyväksytyjä teknisiä sääntöjä sekä sovellettavia lakeja ja direktiivejä.

Nämä arvot ovat järjestelmään liittyviä. Pyydä sitovaa tietoa järjestelmän toimittajalta.



Bemærk

(DK)

Følg de generelle installations-/anvendelsesanvisninger samt brugs- og serviceanvisningerne fra firmaet Gustav Klauke, herunder de relevante skrevne noter om anvendelsesområdet samt systemleverandørens installations- og anvendelsesanvisninger.

Overhold de aktuelle generelt accepterede tekniske forskrifter samt al relevant lovgivning og direktiver for den tilsligtede installation/anvendelse.

Disse værdier er system-relaterede. Kontakt din



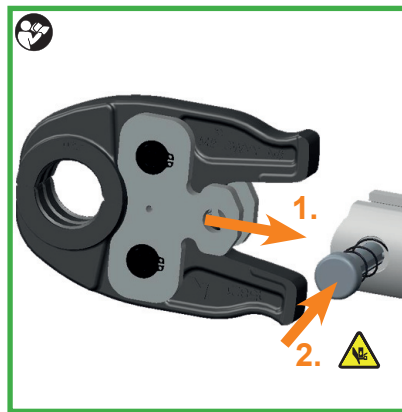
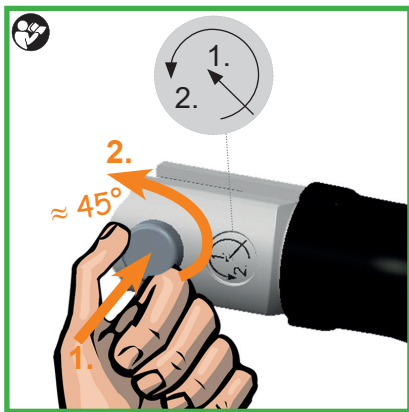
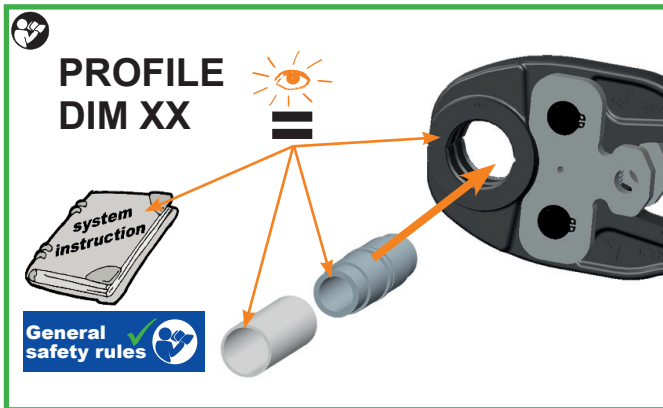
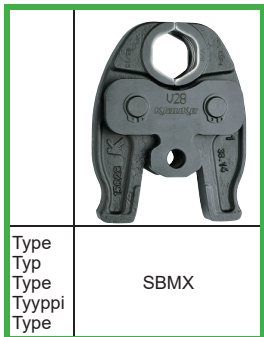

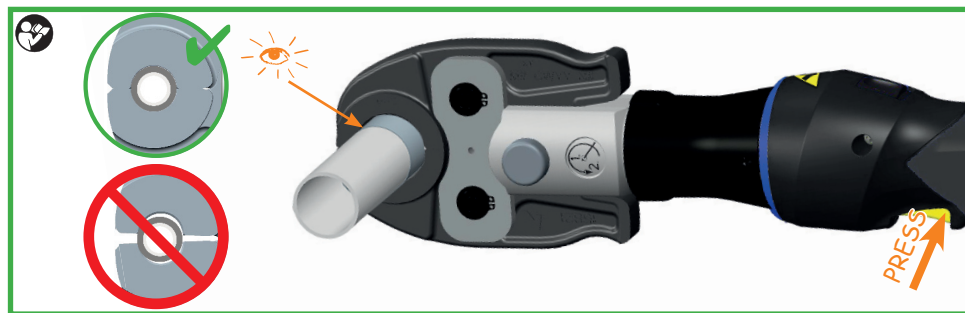
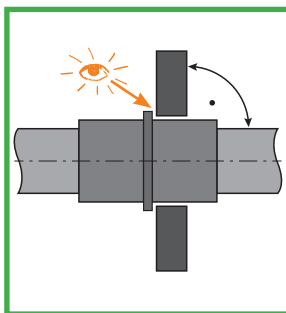
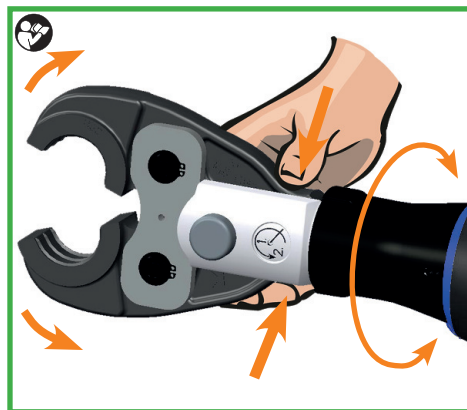



LK Minipress V3-19kN

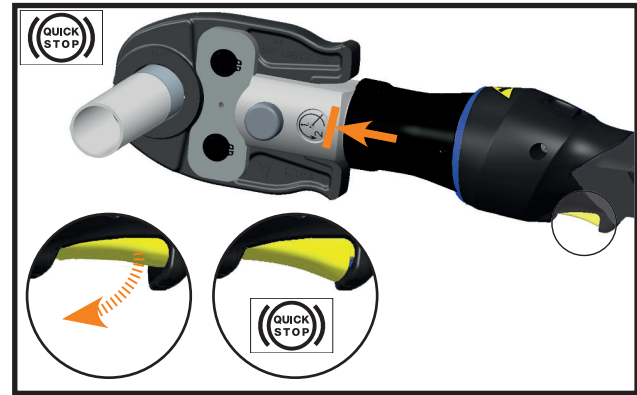
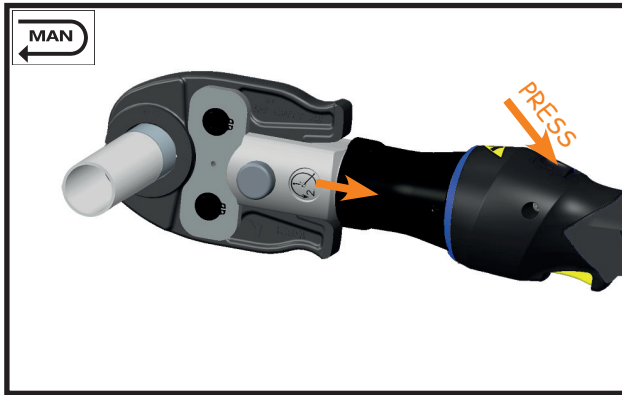
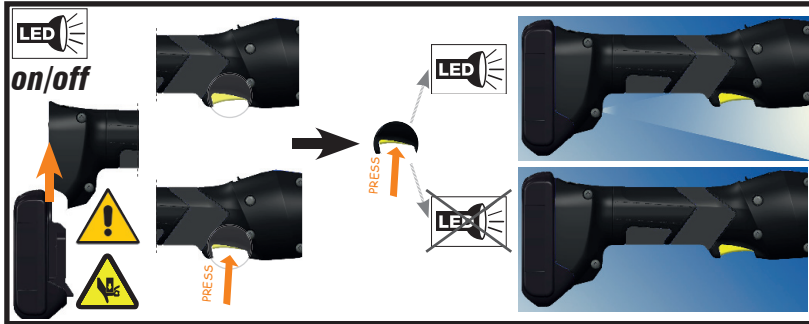



3 years or 10.000 operations
 3 år eller 10 000 cykler
 3 år eller 10 000 sykluser
 3 vuotta tai 10 000 jaksoa
 3 år eller 10.000 cykler



Klauke ASC
 Authorised Service Center

once a year

Recommendation
Empfehlung

Klauke ASC
 Authorised Service Center

Klauke ASC
 Authorised Service Center

-
-
-

WEEE 2012/19/EU

Klauke-WEEE-Abholung@Emerson.com

Klauke

2 years Warranty

World wide Tool Service

ACHTUNG! Bei Beschädigung Garantiesiegel
ATTENTION! Warranty seal if broken

Garantiesiegel
ing Garantieverlust

2 years Warranty

World wide Tool Service

WORK

SERVICE

DON'T DO

General safety rules



Makita® BL1840 IEC61960 18V \approx 4.0Ah 72Wh			Makita® Li-ion		
Li-ion		Li-ion Ni			
Makita Corporation 81035A7			Makita Corporation Anjo, Aichi, Japan Made in Japan		

(BL1840) 36 min.
 RAL40
 (BL1815) 15 min.
 RAL1
 10 - 40°C



Makita®

DC18RC

Li-ion & Ni-MH 7.2-18V

Makita® DC18RC T

Prim.: 220V-240V ~ 240W 50-60Hz
 Sek.: 7.2V-18V \approx 9A

0505611

T4A

CH.P/N:630718-5

Makita Corporation 091990-6



#884676B996
 #884598C990



All manuals are also available on www.Klauke.com / Alla manualer finns tillgängliga på www.Klauke.com / Alle håndbøker finnes også på www.Klauke.com / Kaikki oppaat ovat saatavilla myös osoitteesta www.Klauke.com / Alle manualer findes også på www.Klauke.com

WORK

SERVICE

DON'T DO

General safety rules



			When/Milloin/Mikor/Når	Why/Miksi/Miért/Hvorfor
 20 sec			After working cycle Efter pressprocess Työskentelyn jälkeen Efter arbeidsprosessen Efter afslutning af arbejdet	
 20 sec/2Hz			After working cycle Efter pressprocess Työskentelyn jälkeen Efter arbeidsprosessen Efter afslutning af arbejdet	
 20 sec/5Hz			While exceeding the temp. limit När temperatur överskrids Yliämpötilan aikana Mens overtemperatur forekommer Ved for høj temperatur	Unit too hot Maskinen överhettad Työkalu on liian kuuma Verktøyet er for varmt Værktøjet er for varmt

GB S FIN N DK





			When/Milloin/Mikor/Når	Why/Miksi/Miért/Hvorfor
 1 x	 1 x	 1 x	<p>After working cycle Efter pressprocess Työskentelyn jälkeen Efter arbeidsprosessen Efter afslutning af arbejdet</p>	<p>Error: the required pressure has not been reached. The operator has interrupted the pressing cycle manually while the motor was not running. Rätt oljetryck har ej uppnåtts eller har återgångsknappen tryckts in innan pressningen är slutförd. Virhe: Vaadittavaa puristuspainetta ei saavutettu. Kyseessä on puristuksen manuaalinen keskeytys moottorin ollessa pysäytettynä. Feil: Nødvendig presstrykk ble ikke oppnådd. Pressingen ble manuelt avbrutt mens motoren sto stille. Fejl: det nødvendige pressetryk blev ikke nået. Der er tale om manuel afbrydelse af pressningen, mens motoren ikke er i gang.</p>
 3 x	 3 x	 3 x	<p>After working cycle Efter pressprocess Työskentelyn jälkeen Efter arbeidsprosessen Efter afslutning af arbejdet</p>	<p>Serious Error: The pressure has not been reached while the motor was running. Allvarligt fel rättoljetryck ej uppnått om felet ej kan avhjälpas kontakta verkstad Vakava virhe: Puristuspainetta ei saavutettu moottorin käydessä. Alvorlig feil: Presstrykket ble ikke oppnådd mens motoren gikk. Alvorlig fejl Pressetrykket blev ikke nået, mens motoren var i gang.</p>

GB S FIN N DK



Handgeführtes batteriebetriebenes Elektrowerkzeug Typ LK Minipress V3-19kN

Klauke

(D) CE-'21 - Konformitätserklärung. Wir erklären in alleiniger Verantwortlichkeit, daß dieses Produkt mit den folgenden Normen oder normativen Dokumenten übereinstimmt: EN 62841-1, EN ISO 12100, EN ISO 13857, EN 28662-1, EN 61000-6-3, EN 61000-6-2, EN 60529, EN 1037 gemäß den Bestimmungen der Richtlinien 2006/42/EG, 2014/30/EU, 2011/65/EU

(GB) CE-'21 - Declaration of conformity. We declare under our sole responsibility that this product is in conformity with the following standards or normative documents: EN 62841-1, EN ISO 12100, EN ISO 13857, EN 28662-1, EN 61000-6-3, EN 61000-6-2, EN 60529, EN 1037 in accordance with the regulations of directives 2006/42/EG, 2014/30/EU, 2011/65/EU

(F) CE-'21 - Déclaration de conformité. Nous déclarons sous notre seule responsabilité que ce produit est en conformité avec les normes ou documents normatifs suivants: EN 62841-1, EN ISO 12100, EN ISO 13857, EN 28662-1, EN 61000-6-3, EN 61000-6-2, EN 60529, EN 1037 conformément aux réglementations des directives 2006/42/EG, 2014/30/EU, 2011/65/EU

(E) CE-'21 - Declaración de conformidad. Declaramos bajo nuestra sola responsabilidad que este producto está en conformidad con las normas o documentos normativos siguientes: EN 62841-1, EN ISO 12100, EN ISO 13857, EN 28662-1, EN 61000-6-3, EN 61000-6-2, EN 60529, EN 1037 de acuerdo con las regulaciones de las directivas 2006/42/EG, 2014/30/EU, 2011/65/EU

(I) CE-'21 - Dichiarazione di conformità. Dichiariamo sotto la nostra esclusiva responsabilità che questo prodotto è conforme alle seguenti norme e documenti normativi: EN 62841-1, EN ISO 12100, EN ISO 13857, EN 28662-1, EN 61000-6-3, EN 61000-6-2, EN 60529, EN 1037 conformemente alle disposizioni delle direttive 2006/42/EG, 2014/30/EU, 2011/65/EU

(P) CE-'21 - Declaração de conformidade. Declaramos sob nossa exclusiva responsabilidade que este produto cumpre as seguintes normas ou documentos normativos: EN 62841-1, EN ISO 12100, EN ISO 13857, EN 28662-1, EN 61000-6-3, EN 61000-6-2, EN 60529, EN 1037 conforme as disposições das directivas 2006/42/EG, 2014/30/EU, 2011/65/EU

(NL) CE-'21 - Konformiteitsverklaring. Wij verklaren en wij stellen ons er alleen voor verantwoordelijk dat dit product voldoet aan de volgende normen of normatieve documenten: EN 62841-1, EN ISO 12100, EN ISO 13857, EN 28662-1, EN 61000-6-3, EN 61000-6-2, EN 60529, EN 1037 overeenkomstig de bepalingen van de richtlijnen 2006/42/EG, 2014/30/EU, 2011/65/EU

(GR) CE-'21 - ΔΗΛΩΣΗ ΣΥΜΜΟΡΦΩΣΗΣ Με αναληψη συλλογικης δηλωνομε: οτι το πορον προιον συμφωνα με τα παρακατω ποστυπα και με τα ηρωτηα που αναφερονται στα σχετικα εγγραφα EN 62841-1, EN ISO 12100, EN ISO 13857, EN 28662-1, EN 61000-6-3, EN 61000-6-2, EN 60529, EN 1037 συμφωνα με τοχς κοινοισμους 2006/42/EG, 2014/30/EU, 2011/65/EU

(S) CE-'21 - Konformitetsdeklaration. Vi förklarar på eget ansvar att denna produkt överensstämmer med följande normer eller normativa dokument: EN 62841-1, EN ISO 12100, EN ISO 13857, EN 28662-1, EN 61000-6-3, EN 61000-6-2, EN 60529, EN 1037 enligt bestämmelserna i direktiverna 2006/42/EG, 2014/30/EU, 2011/65/EU

(DK) CE-'21 - Konformitetserklæring. Vi erklærer under almindeligt ansvar at dette produkt er i overensstemmelse med følgende normer eller normative dokumenter: EN 62841-1, EN ISO 12100, EN ISO 13857, EN 28662-1, EN 61000-6-3, EN 61000-6-2, EN 60529, EN 1037 i henhold til bestemmelserne i direktiverne 2006/42/EØF, 2014/30/EU, 2011/65/EU

(N) CE-'21 - Konformitetserklæring. Vi erklærer på eget ansvarighet at dette produkt er i overensstemmelse med følgende standarder eller standard-dokumenter: EN 62841-1, EN ISO 12100, EN ISO 13857, EN 28662-1, EN 61000-6-3, EN 61000-6-2, EN 60529, EN 1037 i henhold til bestemmelserne i direktive ne 2006/42/EØF, 2014/30/EU, 2011/65/EU

(FIN) CE-'21 - Todistus standardinmukaissuudesta. Asiaasta vastaavana todistamme täten, että tämä tuote on seuraavien standardien ja standardoimisasiakirjojen vaatimusten mukainen: EN 62841-1, EN ISO 12100, EN ISO 13857, EN 28662-1, EN 61000-6-3, EN 61000-6-2, EN 60529, EN 1037 ja vastaa säädöksiä 2006/42/EG, 2014/30/EU, 2011/65/EU

(SK) CE-'21 - Prehlásenie o zhode. Prehlasujeme na vlastnú zodpovednosť, že tieto produkty sú v súlade s nasledovnými normami: EN 62841-1, EN ISO 12100, EN ISO 13857, EN 28662-1, EN 61000-6-3, EN 61000-6-2, EN 60529, EN 1037 a v zhode so smernicami 2006/42/EG, 2014/30/EU, 2011/65/EU

(PL) CE-'21 - Zgodność z dyrektywami CE. Świadomy odpowiedzialności oświadczamy, że niniejszy produkt jest zgodny z następującymi normami lub dokumentacją normatywną: EN 62841-1, EN ISO 12100, EN ISO 13857, EN 28662-1, EN 61000-6-3, EN 61000-6-2, EN 60529, EN 1037 zgodnie z postanowieniami wytycznych 2006/42/EG, 2014/30/EU, 2011/65/EU

(CZ) CE-'21 - Prohlášení o shode. Prohlasujeme na vlastní zodpovednosť, že tyto produkty splňují následující normy nebo normativní listiny: EN 62841-1, EN ISO 12100, EN ISO 13857, EN 28662-1, EN 61000-6-3, EN 61000-6-2, EN 60529, EN 1037; Ve shode se smernicami 2006/42/EG, 2014/30/EU, 2011/65/EU

(SLO) CE-'21 - Izjava o skladnosti. S tem potrjujemo splošno odgovornost, da je ta izdelek narejen v skladu z navedenimi normami in standardi: EN 62841-1, EN ISO 12100, EN ISO 13857, EN 28662-1, EN 61000-6-3, EN 61000-6-2, EN 60529, EN 1037 ter določbami in smernicami 2006/42/EG, 2014/30/EU, 2011/65/EU

(HR) CE-'21 - Izjava o skladnosti. Pod punom odgovornošću izjavljujemo da je proizvod naveden u naslovu ovog dokumenta sukladan sa primijenjenim normama i normativnim dokumentima: EN 62841-1, EN ISO 12100, EN ISO 13857, EN 28662-1, EN 61000-6-3, EN 61000-6-2, EN 60529, EN 1037 u skladu sa odredbama preporuka 2006/42/EG, 2014/30/EU, 2011/65/EU

(H) CE-'21 - Megfelelőeségi nyilatkozat. Kéziműködtetésű elektromos kéziszerszámok: Teljes felelősséggel kijelentjük, hogy ezek a termékek a következő szabványokkal és irányelvekkel összhangban vannak: EN 62841-1, EN ISO 12100, EN ISO 13857, EN 28662-1, EN 61000-6-3, EN 61000-6-2, EN 60529, EN 1037; és megfelelnek a rendeltetés szerinti 2006/42/EG, 2014/30/EU, 2011/65/EU irányelveknek.

(RO) CE-'21 - Declarație de conformitate. Noi declarăm pe propria răspundere că acest produs este în conformitate cu următoarele norme și documente normative: EN 62841-1, EN ISO 12100, EN ISO 13857, EN 28662-1, EN 61000-6-3, EN 61000-6-2, EN 60529, EN 1037; potrivit dispozițiilor directivelor 2006/42/EG, 2014/30/EU, 2011/65/EU

Remscheid, 11.11.2021



Joh. - Christoph Schütz

Dipl.-Ing. Joh.-Christoph Schütz, CE-Representative



LK Serviceverkstad *Service med specialistkompetens*

SERVICE | KALIBRERING | REPARATION | KALLELSE TILL ÅRLIG SERVICE

Nu kan du serva dina
LK-pressverktyg hos oss



**Boka service
på nätet**



www.lksystems.se/serviceverkstad



026-54 26 40



Strömmavägen 2, 803 09 Gävle

All SERVICE, REPARATION och KALIBRERING utförs i vår auktoriserade verkstad i Gävle av våra specialiserade och certifierade servicetekniker.